

Checking correct billing system using GSM modem with Wireless SCADA

Vikas Kumar, EE Department, BKBIET, Pilani, Rajasthan, India
vicky.bkbiet@gmail.com

Abstract: Energy meter are monitored using automatic meter reading systems. The data acquired using these systems are sent through SMS whenever requested by service provider. GSM digital power meters are installed in every consumer units and electricity billing system is used at the provider side. Data base servers located at electricity board station are used to store the data obtain through sms system. This data is further processed by energy provider. A GSM digital power meter is a single phase IEC61036 standard compliance digital kwh power meter with embedded GSM modem which utilize the GSM network to send its power usage reading using short messaging system. Billing system is used to manage all meter readings, compute the billing cost and update the data base. SMS, email, web portal, and printed postage are used to publish billing notification to customers. We have built a working prototype to demonstrate effectiveness of billing system using a GSM networks to transfer data.

1. INTRODUCTION

The microcontroller takes the reading from the energy meter and displays the reading on the LCD duly interface to a microcontroller. The reading of the energy meter is sent to the cell phone by a message through GSM modem being fed from the microcontroller and level shifter IC and RS232 link.

The power supply consists of a step down transformer 230/12V, which steps down the voltage to 12V AC. This is converted to DC using a Bridge rectifier and it is then regulated to +5V using a voltage regulator. Which is required for the operation of the microcontroller and components.

SCADA system is collects data from various sensors at a factory, plant or in other remote locations and them sends this data to a central computer which then manages and controls the data. SCADA is a term that is used broadly to portray control and management solutions in a wide range of industries. Some of the industries where SCADA is used are water management systems, electric power, traffic signals, mass transit systems, environmental control systems and manufacturing systems.

3. BLOCK DIAGRAM

In this block diagram, 89S52 microcontroller is interfaced with SIM 300T GSM modem to decode the received message and do the required action. The protocol used for the communication between the two is AT command. The microcontroller pulls the SMS received by phone, decode it, recognizes the mobile

number and then switches on the relays attached to its port to control the appliances. After successful operation, controller sends back the acknowledgement to the user's mobile through SMS.

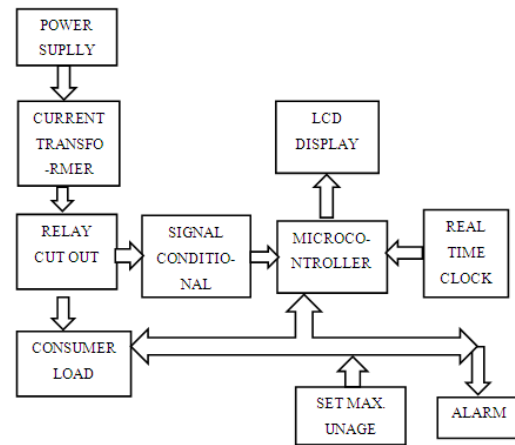

4. Sensor

1. A thermistor is used here as a heat sensor
2. When temperature in the vicinity of thermistor increases, the value of the resistance is decreased in case of fire. The voltage is compared with other input and produce voltage at relay and the relay gets activated. When the relay is activated it sends negative voltage to the microcontroller. The microcontroller sends the SMS to the concerned people

5. ADC

A/D converters convert an analog voltage to the digital output. The output of the various

parameters is fed to A/D converter. The channel selection depends upon the address selection sent by the microcontroller. For ADC to start converting the data after selecting the channel by sending the address inputs, the start conversion signal is to be sent by microcontroller. Then ADC starts converting the analog signal voltage into corresponding digital data. After conversion, the ADC generates EOC (End of Conversion). This indicates to microcontroller that the conversion is completed.

IN3	1	28	IN2
IN4	2	27	IN1
IN5	3	26	IN0
IN6	4	25	ADD A
IN7	5	24	ADD B
START	6	23	ADD C
EOC	7	22	ALE
2 ⁻⁵	8	21	2 ⁻¹ MSB
OUTPUT	9	20	2 ⁻²
ENABLE			
CLOCK	10	19	2 ⁻³
V _{CC}	11	18	2 ⁻⁴
V _{REF} (+)	12	17	2 ⁻⁸ LSB
GROUND	13	16	V _{REF} (-)
2 ⁻⁷	14	15	2 ⁻⁶

Pin diagram of AT89S52

Features of ADC0809

1. Easy interface to all microprocessor
2. Operates ratio metrically or with 5V dc or analog span adjusted voltage reference
3. No zero or full scale adjust required
4. 8-channel multiplexer with address logic
5. 0V to 5V input range with single 5V power supply

6. Regulated Power Supply

The circuit needs two different voltages, +5V and +12V to work. These dual voltages are supplied by this specially designed power supply. The main object of this power supply is to deliver the required amount of stabilized and pure power to the circuit.

The power supply consists of a step down transformer 230/12V, which steps down the voltage to 12V AC. This is converted to DC using a Bridge rectifier and it is then regulated to +5V using a voltage regulator 7805 which is required for the operation of the microcontroller and other components.

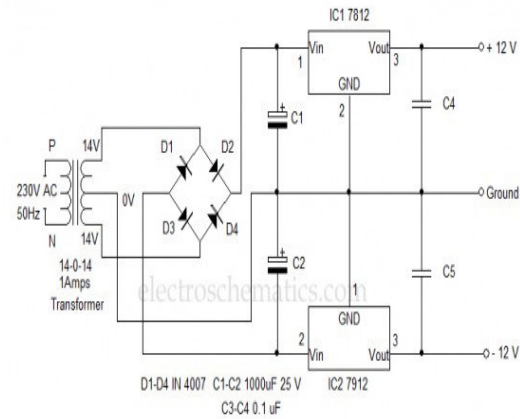

Regulated Power Supply

7. GSM modem (900/1800 MHz)

A GSM modem is a wireless modem that works with a GSM wireless network. A wireless modem behaves like a dial-up modem. The main difference between them is that a dial-up modem sends and receives data through a fixed telephone line while a wireless modem sends and receives data through radio waves. A GSM modem can be an external device or a PC card/PCMCIA card. Typically an external GSM modem is connected to a computer through a serial cable or a USB cable. Like a GSM mobile phone, a GSM modem requires a SIM card from a wireless carrier in order to operate. Computers use AT commands to control modems. Both GSM modems and dial up modems support a common set of standard AT commands. In addition to the standard AT commands, GSM modems support an extended set of AT commands. These extended AT commands are defined in the GSM standards.

8. SERIAL COMMUNICATION USING RS232

RS 232 stands for Recommend Standard number. Most new PC's are equipped with male D type connectors having only 9 pins. Since RS232 is not compatible with microcontrollers we need a voltage converter to convert the RS232 signals to TTL voltage levels. These are acceptable to the microcontroller TxD and RxD pins. The MAX 232 converts the RS232 voltage levels to TTL voltage levels and vice versa.

The chip uses +5v power source which is the same as the power source for the microcontroller. It provides 2-channel RS232C (7) port and requires external 10uF capacitors.

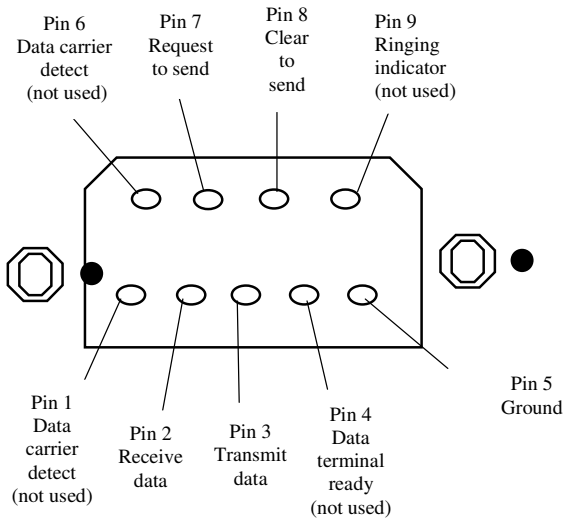

The most common connector used for the 44780 based LCDs is 14 pins in a row with pin centres 0.100” apart.

Pin no.	Name	Description
1	VSS	Power supply (GND)
2	VCC	Power supply
3	VEE	Contrast adjust
4	RS	0=Instruction 1=Data input
5	R/W	0=Write to LCD module 1=Read from LCD module
6	EN	Enable signal
7	D0	Data bus line 0 (LSB)
8	D1	Data bus line 1
9	D2	Data bus line 2
10	D3	Data bus line 3
11	D4	Data bus line 4
12	D5	Data bus line 5
13	D6	Data bus line 6
14	D7	Data bus line 7 (MSB)

9. RELAY

A relay is an electrical switch that uses an electromagnet to move the switch from the off to on position instead of a person moving the switch. It takes a relatively small amount of power to turn on a relay but the relay can control something that draws much more power.



Relay

10. LCD (Liquid Crystal Display)

LCDs can add a lot to any application in terms of providing a useful interface for the user, debugging an application or just giving it a “professional” look. The most common type of LCD controller is the Hitachi 44780 which provides a relatively simple interface between a processor and an LCD [6]. Using this interface is often not attempted by inexperienced designers and programmers because it is difficult to find good documentation on the interface.

11. MICRONTROLLER (AT89S52)

The AT89S52 is a low-power, high-performance CMOS 8-bit microcontroller with 8K bytes of in-system programmable Flash memory. The device is manufactured using Atmel’s high-density non-volatile memory technology and is compatible with the Industry standard 80C51 instruction set and pin out. The on-chip Flash allows the program memory to be reprogrammed in-system or by a conventional non-volatile memory programmer [4] [5] [8]. By combining a versatile 8-bit CPU with in-system

programmable Flash on a monolithic chip, the Atmel's AT89S52 is a powerful microcontroller which provides a highly-flexible and cost-effective solution to many embedded control application.

(T2) P1.0	1	40	VCC
(T2 EX) P1.1	2	39	PO.0 (AD0)
P1.2	3	38	PO.1 (AD1)
P1.3	4	37	PO.2 (AD2)
P1.4	5	36	PO.3 (AD3)
(MOSI) P1.5	6	35	PO.4 (AD4)
(MISO) P1.6	7	34	PO.5 (AD5)
(SCK) P1.7	8	33	PO.6 (AD6)
RST	9	32	PO.7 (AD7)
(RXD) P3.0	10	31	EA/VPP
(TXD) P3.1	11	30	ALE/PROG
(INT0) P3.2	12	29	PSEN
(INT1) P3.3	13	28	P2.7 (A15)
(TO) P3.4	14	27	P2.6 (A14)
(T1) P3.5	15	26	P2.5 (A13)
(WR) P3.6	16	25	P2.4 (A12)
(RD) P3.7	17	24	P2.3 (A11)
XTAL2	18	23	P2.2 (A10)
XTAL1	19	22	P2.1 (A9)
XTAL0	20	21	P2.0 (A8)

Pin diagram of (AT89S52)

Features

1. Compatible with MCS@-51 Products
2. 8K Bytes of In-System Programmable (ISP) Flash Memory
3. 4.0V to 5.5V Operating Range
4. Crystal Frequency 11.0592MHZ
5. Three-level Program Memory Lock
6. 256 x 8-bit Internal RAM
7. 32 Programmable I/O Lines
8. Three 16-bit Timer/Counters
9. Eight Interrupt Sources
10. Full Duplex UART Serial Channel
11. Watchdog Timer

12. WOKING

At each blink of LED of meter reading, a signal is passed to the microcontroller to count the pulses of meter reading. Then microcontroller updates the reading and displays it over LCD and also saves it to the memory. The LCD and memory are connected to port 0 of microcontroller. For transferring the data a GSM modem is used, which sends SMS to the particular mobile number defined. The MAX232 is used to interface GSM modem,. The home unit consists ofa LCD display unit and a GSM modem connected to microcontroller with MAX232 using serial communication port RS232.The major

component of the home interface is the microcontroller ATMEL AT89S52 which has a 256 bytes of RAM memory. The unique id which is assigned to each home unit is stored in this memory. The microcontroller checks the message which reaches from the central EB office, if the destination id matches its id then the work is done else the message is discarded. The home unit is connected to the EB office via GSM which transmit data to the EB office. The microcontroller automatically sends the number of units consumed by the customer to the EB office after a particular duration of time say two months. This message is used to update the back end database and the computation is done. The EB office sends the bill back to the home unit which is displayed on the LCD display. The user is also intimated by an SMS which is sent to his/her mobile phone. Power theft identification is done by means of an alarm, which is connected to the 39th pin of IC AT89S52. Once the alarm is set on, the resetting of the controller can be done by connecting a push button to pin 9.

14. FLOW CHART FOR WIRELESS SCADA

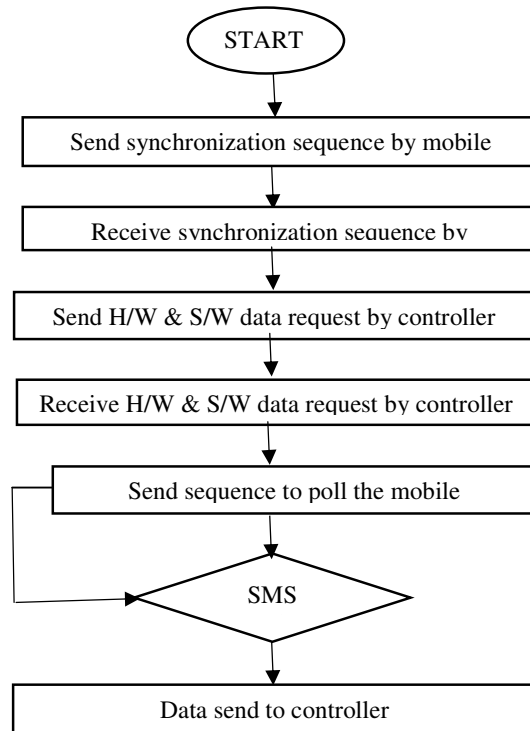

15. ADVANTAGES

1. No problems due to faulty and non-reading meters
2. The customer is free from maintaining past records
3. No meter reading problem due to the door locked cases

4. The main advantage is avoiding the problem of tariff collection
5. Detection of tampering and power theft
6. The number of cards released by electricity can predetermine load
7. The gain good will from consumer
8. The man power is decreased considerably and recording of energy meter reading and preparation of bills for other consumers is simplified

16. APPLICATIONS

1. Home purpose
2. Industrial
3. School and college
4. Commercial shops and office.

17. CONCLUSION AND RESULT

The proposed methodology is used to generate prepaid card for usage of electricity for all areas by the use of GSM technology. This method generates the message to the consumers either by day basis or weekly basis as per consumer requirements and also by the request of consumer at a moment. This technology will minimize the wastage of electricity and saves the power for future generation network infrastructure provides efficient wireless automatic meter reading,

18. REFERENCES

1. Alexander, R.L., Intelligent electronic device (IED) technology SCADA and 3-phase metering, Rural Electric Power Conference, 2002.2002 IEEE, 5-7 May 2002.
2. Sandip C.Patel, Pritimoy Sanyal "Securing SCADA System "Information Management & Computer Security Journal Volume: 16 .Issue:4 Page: 398-414 year: 2008
3. Sungmo Jung, Jae-gu Song, Seoksoo Kim, "Design on SCADA Test-bed and Security Device," International
4. Journal of Multimedia and Ubiquitous Engineering, Vol. 3, No. 4, October, 2008
5. Sandip C.Patel, Pritimoy Sanyal" Securing SCADA System" Information Management & Computer
6. Motorola Semiconductor Technical Data, Technical Summary: 16-Bit Microcontrollers, Motorola Inc, .1997
7. Ricardo B.Uribe," Experiment #10:Introduction to a Programmable Microcontroller," Class notes for ECE 249,Department of Electrical and

- Computer Engineering, University of Illinois, Urbana, Fall 1999.
8. BPI-216 Serial LCD Modules, User's Manual, Scott Edwards Electronics Inc, Jul.2000.
9. Textbook of Muhammed Ali Mazidi, the 8051 Microcontroller and embedded systems
10. Textbook of Kenneth J Ayala, the 8051 Microcontroller
11. Textbook of I Scott Mackenzie, Raphael C.-W. Phan, the 8051 Microcontroller, 4th Edition
12. Principles and Applications of GSM by Vijay K Garg.